

Numerical Simulation and Defect Analysis in the Casting of the Nodular Cast Iron Truck Rear Axle

Y. Sun¹, J. Luo¹, G.F. Mi², X.J. Wang¹ and X. Lin³

¹State Key Laboratory of Mechanical Transmission, Chongqing University, Chongqing 400030, China

²College of Material Science and Engineering, Henan Polytechnic University, JiaoZuo 454000, China

³State Key Laboratory of Solidification Processing, Northwestern Polytechnical University, Xi'an 710072, China

Abstract *The paper analyzes the reasons of some typical defects such as shrinkage porosity (macro or micro), shrinkage cavity, cold shut, segregation and hot crack which occurring the truck rear axle casing using nodular cast iron during the casting process. A three-dimensional (3D) CAD engineering model is created by the Pro/E software, one 3D FDM (Finite Difference Methods) numerical solidification model and Z-CAST simulation software are used to study the casting solidification of the rear axle casing using nodular cast iron. Based on the simulation research results, the structure design of the truck rear axle casing is improved and the casting technique is developed, these simulations and experiments show that these optimization methods are contribute to reduce the casting defect and improve the product quality.*

Keywords *Pouring System, Mold Filling, Solidification, Simulation, Casting Technique*

1.Introduction

As an important component of truck, the rear axle casing need to withstand the bending stress, torque stress and fatigue during truck transport (Takeda 1994), so the rear axle casing will have a good comprehensive mechanical properties and behaviors (such as, high strength and good toughness) by a good casting (Pinkaw 2007). The general manufacture technique of a truck rear axle is casting technology, and the general material for manufacturing the truck rear axle is nodular cast iron which is of some good casting characteristics and behaviors (Wang, 2003). But as a result of graphite expansion action and effect, which can lead to the fluid feeding channel is blocked and lose the feeding ability in later period of casting solidification, so many kinds of defects will present in the casting, such as cavity, shrinkage and crack. On the other hand, the structure of pouring system and casting technology can affect the stability on casting mold filling and solidification process, when the casting mold filling is lack of physical stability, it can lead to splashing, spatter, gas evolved and molten metal oxidized etc., the formation of casting defects includes sand burning, pore, oxidation and slag (Wei, 1996). These above defects reduce casting strength, toughness and quality of the truck rear axle, which is very dangerous to a truck transport. Many experimental studies on casting technology are carried out in order to improve casting quality of a truck rear axle and to guarantee the safety of truck transport (Pinkaw 2007; Huang 2004; Gui 2004). In previous research works, these issues are usually dealt with according to personal intuition and experience(Wei,1996; Liu, 2005), the cost of this traditional research method is very high and the time is more. Now the CAD/CAM/CAE techniques are employed to cope with optimization design in casting process (Wu, 2005; Luo, 2006), which is a more efficiently and low-cost method and can save a plenty of time (Luo, 2007; Mi, 2007).

The paper is supported by the Natural Science Foundation Project of CQ CSTC2008BB3303 and the Program for New Century Excellent Talents in University (NCET-08-0607).

The paper will study the casting process of the truck rear axle casing by the numerical simulation method, and then improve the casting technology and casting structure in order to improve the defects of the truck rear axle casing.

2. Analysis of Casting Defects

2.1 Structure and material of the truck rear axle casing

Fig.1 shows that structure of the truck rear axle casing, which is a symmetrical structure, the middle part of the truck rear axle casing is a rotator with an internal flange, the two waist parts are a smoothing transitional surface from the rotator, and there has a internal cavity structure with some small sidesteps. The truck rear axle casing has some groove, sidesteps and flanges, the internal mould cavity structure of the rear axle casing is a main structure forms, which is made up of complex geometrical structure. The basic size of the rear axle casing is 1559mm×448mm×196mm, the thinnest wall of the rear axle casing is 10mm, the thickest part of the rear axle casing is 20mm, and the average thickness of the rear axle casing is 15mm.



Fig.1. Structure of the rear axle casing

The nodular cast iron is used to manufacture the truck rear axle casing. The type of material is QT450-10 (Trademark in China.), which is ferrite type nodular cast iron. This kind of nodular cast iron includes a high C and Si element contents, the content of P and S element are in a low level, the nodular cast iron has a good fluidity and casting behaviors. So the casting defects such as misrun, cold-shut is difficult to appear in the casting workpiece at an appropriate temperature and reasonable pouring system condition, the casting workpiece has a good mechanical properties (strength and toughness).

2.2 Casting defects of the truck rear axle casing

Fig.2 shows an old pouring system of the truck rear axle casing, which is used in the actual casting process at some factory. The pouring system locates at the legs of the truck rear axle casing, and has two casting ladles and two risers. This structure design of pouring system is of compact and simple characteristics, it is advantageous to a good mold filling and save molten metal on the casting process.

The shortcoming of this pouring system in Fig.2 is as following by the experimental studies and theory analysis:

(1) There are two casting ladles. because the two casting ladles must work simultaneously, so this pouring system makes the casting technology complex and casting quality controlling difficult.

(2) There are some differences of casting temperature and beginning time between the two casting ladles, so the casting temperature field is not uniformly at the two sides of the truck rear axle casing, which disturbs the direction of heat transfer, temperature gradient and solidification process, so the casting workpiece is likely to present many defects (such as shrinkage) at the later period of casting solidification.

(3) This pouring system increases the instability of mould filling when the molten metal liquid is poured into two independent casting ladles at same time. It is very possible that the sand

burning, splashing, spatter, gas evolved, slag and molten metal oxidized take place in the casting process, which has a bad effect on the casting quality.

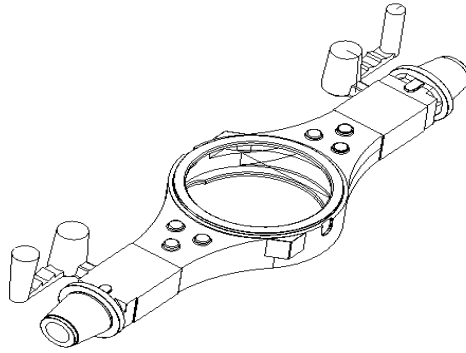

Fig.2. The old pouring system



(a) Slag



(b) Sand burning

Fig.3. The casting defects

Fig.3 shows an actual typical appearance casting defects of the rear axle casing, such as slag and sand burning, by adopting this pouring system.

3.New Pouring System Design and Technology Optimization

3.1 New pouring system design

Based on actual experiments and above analysis, the Pro/E software is used to establish the three-dimensional (3D) CAD engineering model for the truck rear axle casing with a new pouring system, the CAD model is one precondition for the structure design and numerical simulation of new truck rear axle casing.

By improving the pouring system and considering many important parameters (such as casting shrinkage rate, machining allowance etc.), a 3D engineering model of the rear axle casing with a new pouring system is designed as shown in Fig.4.

The CAD model is saved as STL format by Pro/E software, in order that the 3D model can be input FDM numerical simulation software for meshing and simulation.



Fig.4. The new pouring system and 3D solid model

3.2 New structure analysis

3.2.1 Model of casting process simulation

The Z-CAST FDM simulation software is used to simulate casting mold filling and solidification process in order to check the pouring system reliability, optimize the structure design and guide the casting technology. The simulation model is shown in Fig.4 which is input from the Pro/E model. The continuity equation, momentum conservation (Navier-Stokes) equation and energy (enthalpy) conservation equation are respectively as following,

$$\frac{\partial u}{\partial x} + \frac{\partial v}{\partial y} + \frac{\partial w}{\partial z} = 0 \quad (1)$$

$$\rho \left(\frac{\partial u}{\partial t} + u \frac{\partial u}{\partial x} + v \frac{\partial u}{\partial y} + w \frac{\partial u}{\partial z} \right) = -\frac{\partial P}{\partial x} + \rho g_x + \mu \nabla^2 u$$

$$\rho \left(\frac{\partial v}{\partial t} + u \frac{\partial v}{\partial x} + v \frac{\partial v}{\partial y} + w \frac{\partial v}{\partial z} \right) = -\frac{\partial P}{\partial y} + \rho g_y + \mu \nabla^2 v \quad (2)$$

$$\rho \left(\frac{\partial w}{\partial t} + u \frac{\partial w}{\partial x} + v \frac{\partial w}{\partial y} + w \frac{\partial w}{\partial z} \right) = -\frac{\partial P}{\partial z} + \rho g_z + \mu \nabla^2 w$$

$$\rho c \frac{\partial T}{\partial t} + \left(\rho c u \frac{\partial T}{\partial x} + \rho c v \frac{\partial T}{\partial y} + \rho c w \frac{\partial T}{\partial z} \right) =$$

$$\frac{\partial}{\partial x} \left(k \frac{\partial T}{\partial x} \right) + \frac{\partial}{\partial y} \left(k \frac{\partial T}{\partial y} \right) + \frac{\partial}{\partial z} \left(k \frac{\partial T}{\partial z} \right) + S \quad (3)$$

Where u, v, w is the velocity on three direction. x, y, z is direction factors. g is the gravity, ρ is density, f is the rate of volume, k is the heat conduction ratio, S is the inner heat source. The details of mathematical model please refer to the User Guide Manual of Z-CAST.

The 3D simulation model is meshed using one uniform method (about 5mm per grid), the meshing numbers of casting solid model is 353×168×90.

3.2.2 Results analysis of mold filling simulation

Fig.5, Fig.6 and Fig.7 are the temperature field when the casting mold filling states is 30%, 60% and 100% respectively. The 30% filling state (in Fig.5) shows that the internal temperature gradient of casting workpiece is small, the temperature at the inlet of ingate is little higher than that of at the bottom of flange. The 60% filling state (in Fig.6) shows the casting temperature of the flange body (in middle of the rear axle casing) is 1300 °C.

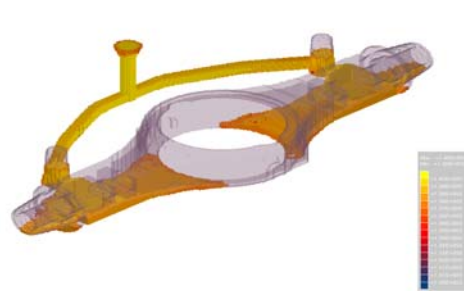

Fig.5. The temperature field about the 30% casting mold filling states

The temperature of two risers and two edges of the rear axle casing are higher than that of the flange body. The molten metal flows into the casting mould steadily through the ingate and long pouring channel, which lies on one side of the casting workpiece. The liquid level of the casting mould rises also steadily in the mold filling process, so the bottom of casting workpiece has little defects about cold shut and feeding insufficiency in this way.

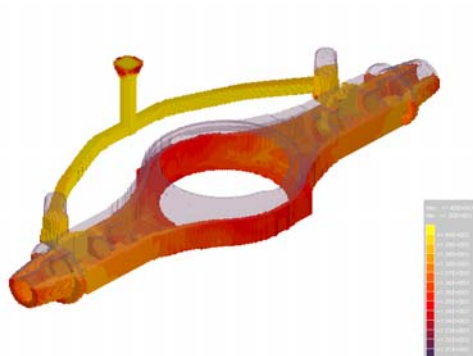

Fig.6. The temperature field about the 60% casting mold filling states

It shows obviously that the casting workpiece establishes a good temperature gradient when the mold filling percent is 100% in Fig.7. The temperature of the risers is higher than that of the casting body. This kind of temperature distribution is helpful to bring into full filling and overflow, and reduce the existences of internal shrinkages defect in the casting workpiece.

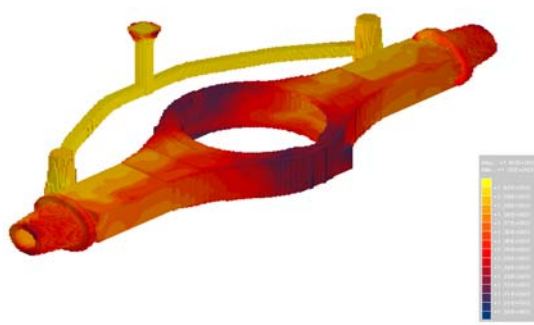

Fig.7. The temperature field about the 100% casting mold filling states

3.2.3 Results analysis of casting solidification simulation

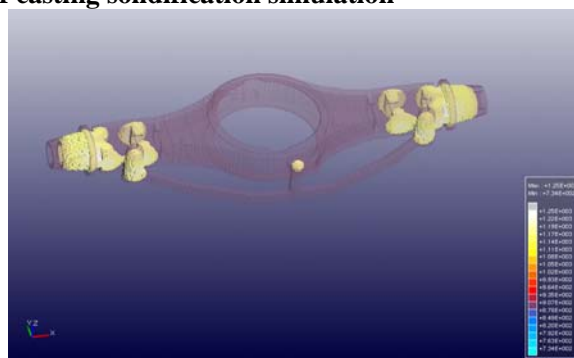

Fig.8. The temperature field about solidification time is 900 second

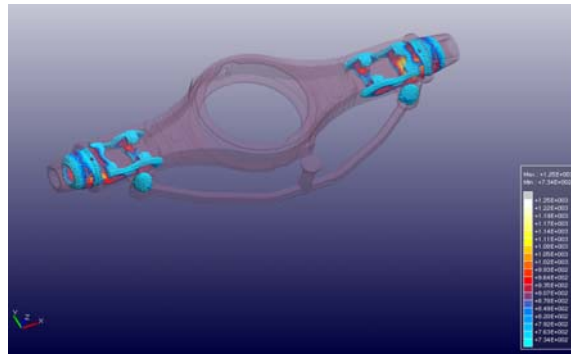

Fig.9. The temperature field about solidification time is 1200 second

At the 1200s solidification final stage (in Fig.9), it shows obviously that solidification speed of the ingate is faster than that of casting body, the temperature of the ingate is lower than that of casting body, so the pouring channel is closed. It makes the risers can not play the role of feeding and overflow at the end period of solidification, and then the expanded solid graphite make metal liquid attempt to flows back into pouring channel from the casting body, so many defects (such as hot crack and shrinkage cavity) take place at this solidification stage.

In addition, there has one interface between the ingate and casting mould, the temperature at combining site where the fluid enter casting mould by the ingate is higher than other parts, it causes the solidification time is long at the combining site, many defects also present at this site, the reason is that the structure of inner channel near this combining site is very complex. So the pouring system , riser and structure of the ingate need to improve.

3.3 Optimization

A new improvement pouring system is designed, the position of the casting ladles and risers are optimized, and one new structure of the ingate at the combining site (between pouring channel and casting workpiece) is proposed, at the aid of the CAD technique(Pro/E software) and many numerical simulations (such as Z-CAST, ProCast and FLUENT softwares) for mold filling and solidification process.

For avoiding early solidification of molten metal in the ingate, the height of the ingate increases from 12mm to 24mm, and the length of the ingate improve from 75mm to 50mm considering the feeding ability of the risers and sand burning ratio. Correspondingly the width of the horizontal runner changes from 22mm to 24mm, the diameter of the sprue bottom part which is located in the middle of the runner adds from 41mm to 43mm, and the position of the riser is also change. The temperature field of the new improvement system is shown in Fig.10 and Fig.11 respectively when the solidification time is 900 second and 1200 second after the mold filling process is finished.

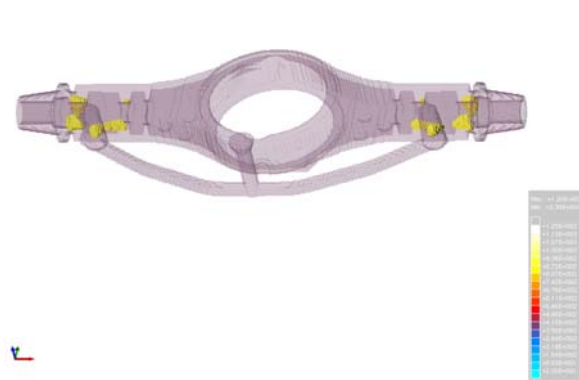

Fig.10. The temperature field about solidification time is 900 second (Improved)

It shows obviously that the temperatures at the ingate and the bottom of riser are higher than that of casting body, so the pouring channel is unblocked and feeding at the final stage of casting solidification, this good temperature distribution in Fig.11 is also helpful to reduce many internal defects in casting workpiece. Compared Fig.9 with Fig.11, the numerical simulation results show that the improvement system is of availability.

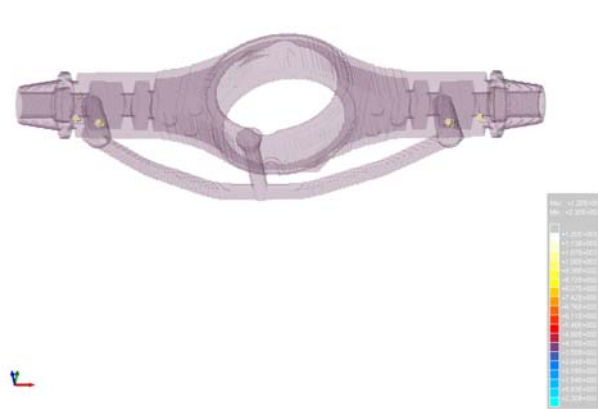

Fig.11. The temperature field about solidification time is 1200 second (Improved)

On the other hand, the truck rear axle casing has a complicated internal structure. In order to improve the casting quality, the internal structure of the truck rear axle casing is also optimized as shown in Fig.12. Cooperated with the optimization of pouring system, the casting technology is improved to suit for the new optimization structure simultaneously. The results of numerical simulation and experiences show that the truck rear axle casing has a good casting profile and high mechanical properties, and the casting production meet the requirement of design and quality.

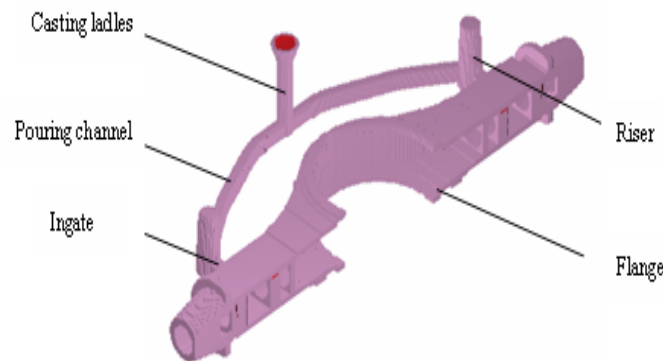

Fig.12. The optimized internal structure and pouring system of casting workpiece

4. Discusses

Compared to Fig.2, the runner of the new pouring system (in Fig. 4) employ a new smooth circle transition structure, which can ensure that molten metal liquid flow steadily from the ingate into the casting workpiece with an uniform speed and adequate quantity, this kind of mold filling method can prevent the fluid form a turbulence state, and avoid the air mixture enter the casting, reduce the defects such as metal oxide, shrinkage porosity (macro or micro).

The new pouring system is also of great benefit to the casting behaviors and improve gases release from molten metal, it can make molten metal liquid feeding and reduce the appearance of slag, shrinkage and hot cracks. At the same time, it is very convenient that workers operate the pouring system, in one word, the integrated methods including the new structure, casting

technology and pouring system are useful to establish effectively an sequential solidification procedure from mid part to two edge part of the truck rear axle casing.

5. Conclusion

The mold filling and casting solidification process of the truck rear axle casing using nodular cast iron are studied. The pouring system and structure of rear axle casing are improved, and the casting technique is developed. The integrated methods including the new casting structure, casting technology and pouring system are useful to establish a great directional and sequential solidification procedure from middle part to two edge part of the truck rear axle casing. The optimization pouring system reduces the defects in casting workpiece. The simulation research results and experiments show that these optimization methods are contributed to reduce the casting defect and improve the product quality.

Acknowledgements

The authors gratefully acknowledge the support of a grant from the Natural Science Foundation Project of CQ CSTC 2008BB3303 and CQ CSTC 2009BA3026, the Ph.D. Programs Foundation of Ministry of Education of China (No.20070611030), the Outstanding Young Scholar Program of Natural Science Foundation of HUBEI Province (No. 2006ABB027), the Program for New Century Excellent Talents in University (NCET-08-0607), CHANGJIANG Scholars and Innovative Research Team in University (IRT 0763), the project of the State Key Laboratory of Mechanical Transmission in Chongqing University and the fund of the State Key Laboratory of Solidification Processing in Northwestern Polytechnical University. The paper is also supported by the Exchange Study Foundation Program of Chongqing University of the Project 211 Tertiary System.

References

- [1] Takeda, Nobuyuki et al. Stress analysis of rear axle case for heavy-duty truck. (Optimum design of rear cover fixed area), Transactions of the Japan Society of Mechanical Engineers, Part A, 60(579) (1994) 2612-2617.
- [2] Pinkaew, Tospol, et al. Experimental study on the identification of dynamic axle loads of moving vehicles from the bending moments of bridges. Engineering Structures, 29(9) (2007) 2282-2293.
- [3] Wang H.L. The casting techniques: Typical automobile workpieces. Polytechnical University Press, Beijing (2003).
- [4] Wei QT. Casting Technology. Xi'an: Northwestern Polytechnical University Press (1996).
- [5] Liu, B.C. Development Trend of Casting Technique and Computer Simulation, Foundry Technology, 26(7) (2005) 611-617.
- [6] Lin Q.A. Pro/Engineering design Guide Beijing: Beijing Univeristy Press (2000).
- [7] G.F.Mi, et al. Development and application of numerical simulation for the mold filling process of casting. Journal of Henan Polytechnical University (Natural Science), 26(3) (2007) 334-339.
- [8] Huang X, et al. Development & research of 13-ton automobile axle casing casting, Automobile Science and Technology, (4) (2004) 27-30.
- [9] Wu C.G, et al, 2007. The Foundry Technology Design and Numerical Simulation of Automotive Rear Axle by Proportional Solidification and Macroporous Outflow, China Foundry Machinery & Technology, (5) (2007) 25-28.
- [10] WU M, et al. Numerical study of the Thermal-Solutal Convection and Grain Sedimentation during Globular Equiaxed Solidification, Material Science Forum, 475-479(5) (2005) 2725-2730.
- [11] Luo J , et al.The 3D simulation of liquid core change of cylinder steel rolling forming on soft-reduction continuous casting process. ISDM2006 International Conference, Oct.15-17,

- 2006, Wuhan, P.R.China. Journal of Wuhan University of Technology, 28 (SI.) (2006) 637-639.
- [12] Luo J, et al. Numerical Study of Liquid Core Solidification in Influence of Soft Reduction Deformation on Steel Slab Continuous Casting Process, Proceedings of The 5th International Conference on Physical and Numerical Simulation of Materials Processing (ICPNS2007), October 23~27, Zhengzhou, P.R.China. Material Science Forum, 575-578 (2008) 80-85.
- [13] Luo J, Luo Q, Lin YH, Xue J. A New Approach For Fluid Flow Model in Gas Tungsten Arc Weld Pool Using Longitudinal Electromagnetic Control. Welding Journal, 82 (8) (2003) 202s-206s.
- [14] Gui Q.S. Casting Technology of Back Bridge Housing, Foundry Technology, 25(5) (2004) 337-339.